



Arklow Maritime Festival Regatta

Sunday 6th August 2017

Arklow Sailing Club

Sailing Instructions

1 Organising Authority and Rules

1.1 The organising authority is the Arklow Sailing Club.

1.2 All competitors are hon. members of ASC for the duration of the event.

1.3 The regatta will be governed by the rules as defined in *The Racing Rules of Sailing (RRS) 2017-2020* and any amendment thereto, the Prescriptions of Irish Sailing (IS), ECHO handicapping system rules, the Notice of Race and these Sailing Instructions (SIs)

2 Notice to Competitors

Notices to competitors will be posted on the official notice board(s) for the event that shall be located in the Arklow Sailing Club.

3 Changes to Sailing Instructions

Any change to the sailing instructions will be posted before 0900hrs on the day it will take effect, except, any change to the schedule of races will be posted by 2000hrs on the day before it will take effect.

4 Signals Made Ashore

4.1 Signals made ashore will be displayed from the Arklow Sailing Club signal mast at the front of the clubhouse.

4.2 When flag AP is displayed ashore, '1 minute' is replaced with 'not less than 60 minutes' in the race signal AP.

4.3 When flag Y is displayed ashore, rule 40 applies at all times while afloat. This changes the Part 4 preamble.

5 Schedule of Race

The following shall be the schedule of races on Sunday 6th 2017

| | Race 1 |
|------------------|-----------------------|
| Class | Warning Signal |
| Cruiser Class I | 10:55 hrs |
| Cruiser Class II | 11.00 hrs |
| White Sails * | 11.00 hrs |
| | |

Race 2 will commence immediately after Race 1

Race 3 will commence immediately after Race 2

*White Sails class shall only exist if sufficient entries are registered

6 Class Flags

Class flags will be:

| Class | Flag | Comment |
|------------------|-------------------|-----------------------|
| Cruiser Class I | Numeral Pennant 1 | Displayed on Backstay |
| Cruiser Class II | Numeral Pennant 2 | Displayed on Backstay |
| White Sails | White | Displayed on Backstay |

7 Racing Area

The Racing Area shall be the waters of Arklow Bay, East Coast of Ireland. This area is covered by Admiralty Charts Number 633 or 1787.

8 The Courses

8.1 The courses to be sailed shall be designated as set out in Appendix 1, 2 and 3

8.2 The course to be sailed will be indicated by displaying:

| International Code Flag | Course |
|--------------------------------|-------------------------|
| Flag "F" | Fixed Mark Course |
| Flag "W" | Windward/Leeward Course |
| Flag "O" | Olympic Style Course |

9 Marks

Marks are described in Attachments 1, 2 & 3.

10 The Start

- 10.1** Races will be started by using rule 26 with the warning signal made 5 minutes before the starting signal.
- 10.2** The starting line will be between a staff displaying an orange flag on the Committee Boat and the starting mark.
- 10.3** Boats whose warning signal has not been made shall avoid the starting area during the starting sequence for other races.
- 10.4** A boat starting later than 15 minutes after her starting signal will be scored “Did Not Start” without a hearing. This changes rule A4.
- 10.5** Starting penalties shall be applied as outlined under rule 30.

11 Change of the next leg of the course

To change the next leg of the course, the race committee will move the original mark (or the finishing line) to a new position.

12 The Finish

- 12.1** When on station at the finish the Committee Boat will display a Blue Flag.
- 12.2** When the Blue Flag is hoisted on the Committee Boat a boat shall not cross the finish line unless finishing.
- 12.3** The finishing line will be between a staff displaying an orange flag on the Committee Boat and the Finishing Mark.

13 Time Limits and Target Times

- 13.1** The time limit for each race and class shall be 2 hours from their valid starting signal except that if any boat in that class finishes within two hours.

13.2 Boats failing to finish within 30 Minutes after the first boat sails the course and finishes will be scored “Did Not Finish” without a hearing. This changes rules 35, A4 and A5.

14 Protests and Requests for Redress

14.1 Protest forms are available at the race office located at Arklow Sailing Club. Protests and requests for redress or reopening shall be delivered there within the appropriate time limit.

14.2 For each class, the protest time limit is 90 minutes after the last boat has finished the last race of the day or the race committee signals no more racing today, whichever is later.

14.3 Notices will be posted no later than 30 minutes after the protest time limit to inform competitors of hearings in which they are parties or named as witnesses.

15 Scoring, Handicaps and Division of Classes

15.1 The Low-point Scoring System shall apply in accordance with RRS Appendix A

15.2 One race is required to be completed to constitute a series.

15.3 When all three races have been completed, a boats series score will be the total of her race scores excluding her worst score. Otherwise a boat’s series score will be the total of her race scores.

15.4 Results will be calculated under the current ECHO/Sail100 progressive handicap system. System parameters can be set by the regatta race committee.

15.5 Class allocation will be based on standard ECHO handicaps with cut off points shown below. If a boat does not have a valid handicap certificate the race committee will assign a suitable rating.

| | |
|----------------------------------|-----------------------------------|
| Cruiser Class I: 0.910 and above | Cruiser Class II: 0.909 and below |
|----------------------------------|-----------------------------------|

15.6 The race committee reserves the right to allocate a boat to any class.

16 Safety Regulations

16.1 A boat that retires from a race shall notify the race committee as soon as possible

17 Replacement of Crew or Equipment

17.1 Substitution of competitors will not be allowed without prior written approval of the race committee.

17.2 Substitution of damaged or lost equipment will not be allowed unless authorized by the race committee. Requests for substitution shall be made to the committee at the first reasonable opportunity.

18 Radio Communication

18.1 The Race Officer will operate on VHF Channel 14 and remind classes of starts, courses and other relevant information. Failure to hear or receive radio transmissions will not be grounds for redress.

18.2 Except in an emergency, a boat shall neither make radio transmissions while racing nor receive radio communications not available to all boats. This restriction also applies to mobile telephones.

19 Prizes

19.1 Prizes shall be awarded to the winner and runner up in each class on Sunday 6th August 2017. First prize trophy shall be awarded to the winner of each feeder race on Saturday 5th August 2017.

20 Disclaimer of Liability

20.1 Competitors participate in the regatta entirely at their own risk. See rule 4, Decision to Race. The organizing authority will not accept any liability for material damage or personal injury or death sustained in conjunction with or prior to, during, or after the regatta.

20.2 The safety of a boat and her crew is the sole and inescapable responsibility of the owner(s) or the owner's representative whose obligation it is to ensure that the boat is fully sound, seaworthy, manned by an experienced crew and equipped with all the necessary safety equipment. Neither these sailing instructions nor any action of the organising authority in any way limits or reduces the complete and unlimited responsibility of the owner(s) or owner's representative.

20.3 Boat owners and competing crew shall ensure that they are adequately insured against loss, damage or injury to persons, boat or equipment at all times and however occurring and shall maintain 3rd party

insurance cover of not less than three million euro(€3,000,000) and shall produce a valid certificate of insurance upon request.

- 20.4** No responsibility shall be accepted by the organising authority, its members, servants or agents, nor those officials or members connected with the event for any loss, damage, injury or other claim of whatever nature howsoever arising or caused in connection with participation in, or intended participation in this event.

Appendix 1

FIXED MARK COURSE (IC Flag “F”)

Arklow Sailing Club Fixed Race Marks

All Classes

- Course is as described by the Race Officer on the day and shall be displayed on the committee boat notice board
- A standard Arklow Sailing Club course card will be supplied in the race pack and should be used as reference only
- The first mark, to be rounded to port, will be an orange inflatable mark, Z, and shall be to windward of the start line
- All other marks are plastic buoys described below
- The starting line will be between a staff displaying an orange flag on the Committee Boat and the Starting Mark
- The finishing line will be between a staff displaying an orange flag on the Committee Boat and the Finishing Mark

| Fixed Race Marks (Approx. Position) | | | Description |
|--|--------------|------------|---------------------------|
| Gypsum | 52°47.840'N, | 6°08.270'W | Red Barrel marked G |
| Lanby | 52°47.290'N, | 6°07.360'W | Grey Barrel marked L |
| Outer | 52°47.840'N, | 6°06.451'W | Black/Red Barrel marked O |
| Porters Rock | 52°48.940'N, | 6°06.800'W | Grey Barrel marked P |
| Roadstone | 52°46.895'N, | 6°08.448'W | Black Barrel marked R |

| | | | |
|-----------------------|--------------|------------|----------------------|
| Turbine | 52°48.390'N, | 6°05.540'W | Grey Barrel marked T |
| Webbs River | 52°48.390'N, | 6°07.360'W | Grey/Red marked W |
| No2 Glasgorman | 52°45.348'N, | 6°05.343'W | Red Cylindrical |

| ASC Fixed Start Triangle (Approx. Position) | | Description | |
|--|--------------------|--------------------|---------------|
| Black | 52°47.902'N, | 6°07.240'W | Grey Barrel |
| Red | 150m East of Grey | | Red Spherical |
| Yellow | 150m South of Grey | | Yellow Barrel |

Appendix 2

WINDWARD / LEEWARD COURSE (IC Flag “W”)

Class I

From the start to
Round 1: Windward 1 - Leeward,
Round 2: Windward 1 - Leeward,
Round 3: Windward 1 - Leeward,
Thence from last mark to Finish line

Class II

From the start to
Round 1: Windward 2 - Leeward,
Round 2: Windward 2 - Leeward,
Round 3: Windward 2 - Leeward,
Thence from last mark to Finish line

- Number of rounds shall be indicated at the warning signal of each class
- Marks are Orange inflatable Buoys
- S/F Mark is an Orange inflatable Buoy
- All marks to be rounded to port

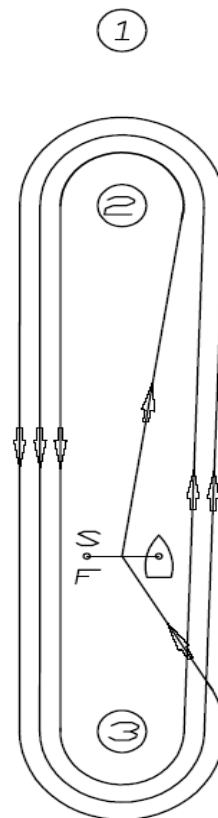
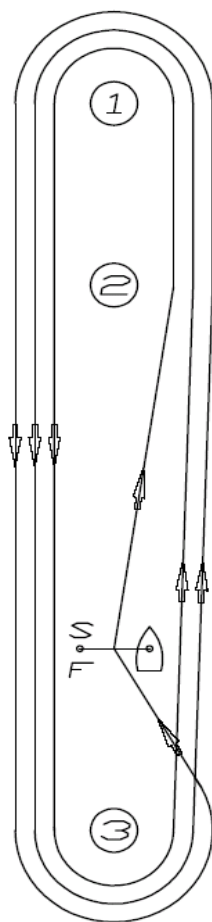

Appendix 3**OLYMPIC TRIANGLE COURSE (IC Flag “O”)**

| Class I | From the start to | Class II | From the start to |
|----------------|--------------------------------------|-----------------|--------------------------------------|
| | Round 1: 1 – 2 – 3 | | Round 1: 1 – 2 – 3 |
| | Round 2: 1 – 3 | | Round 2: 1 – 3 |
| | Round 3: 1 – 2 – 3 | | Thence from last mark to Finish line |
| | Thence from last mark to Finish line | | |

- Number of rounds shall be indicated at the warning signal of each class
- Mark are orange inflatable Marks
- S/F Mark is an orange inflatable buoy
- All marks to be rounded to port

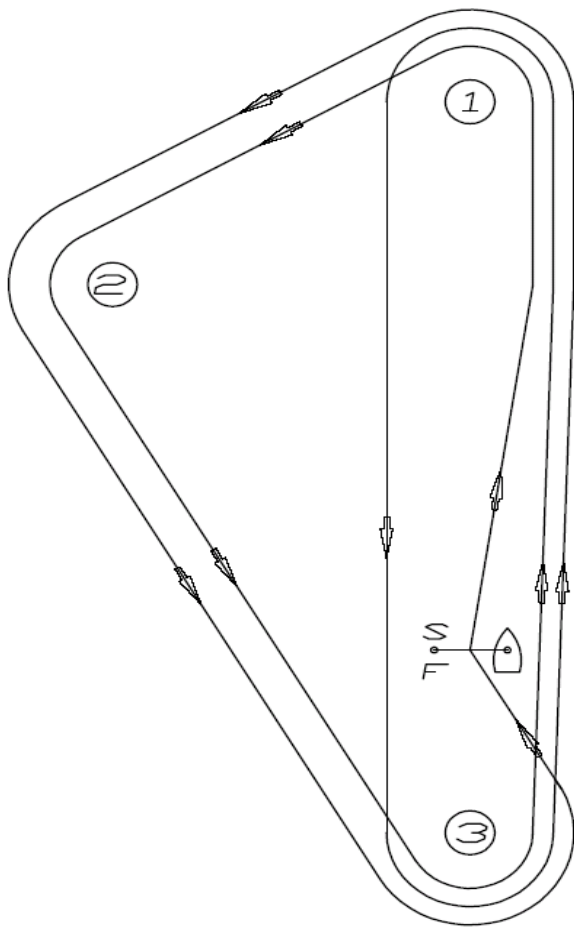

CLASS I – OLYMPIC TRIANGLE COURSE

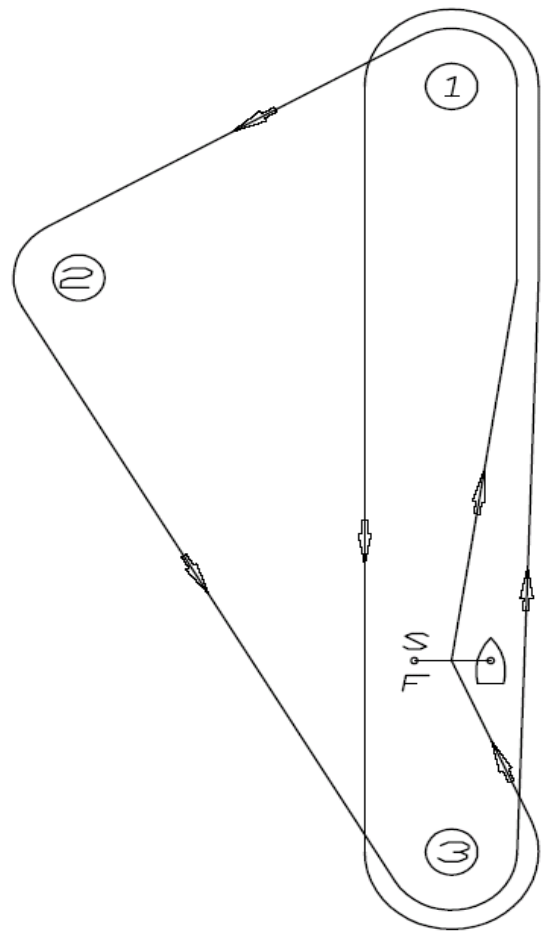

CLASS II – OLYMPIC TRIANGLE COURSE